

# SIEMENS

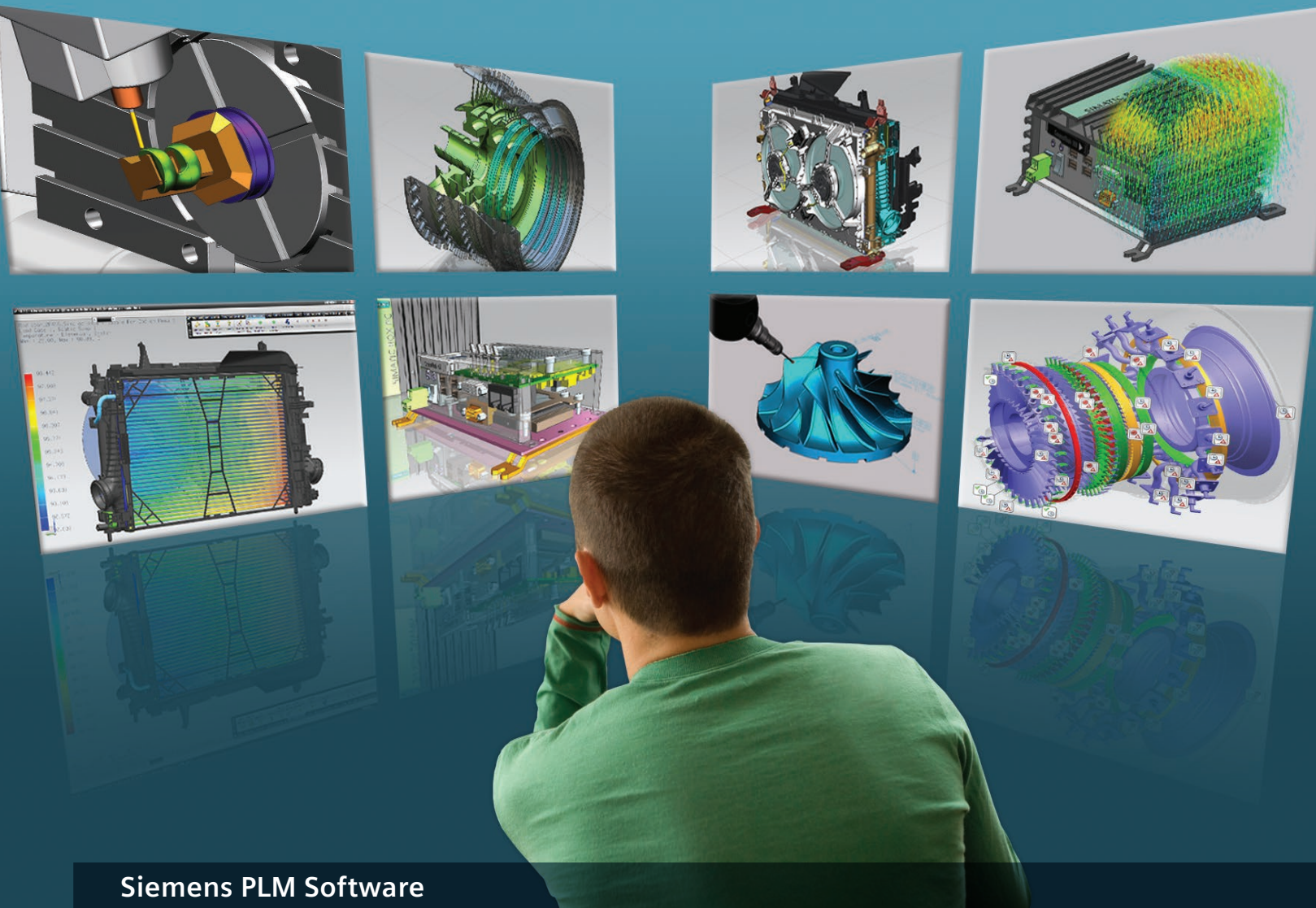

Siemens PLM Software

# NX

Transforming the entire product development process with high-performance, integrated solutions for design, simulation and manufacturing

[siemens.com/nx](https://www.siemens.com/nx)



# The NX advantage

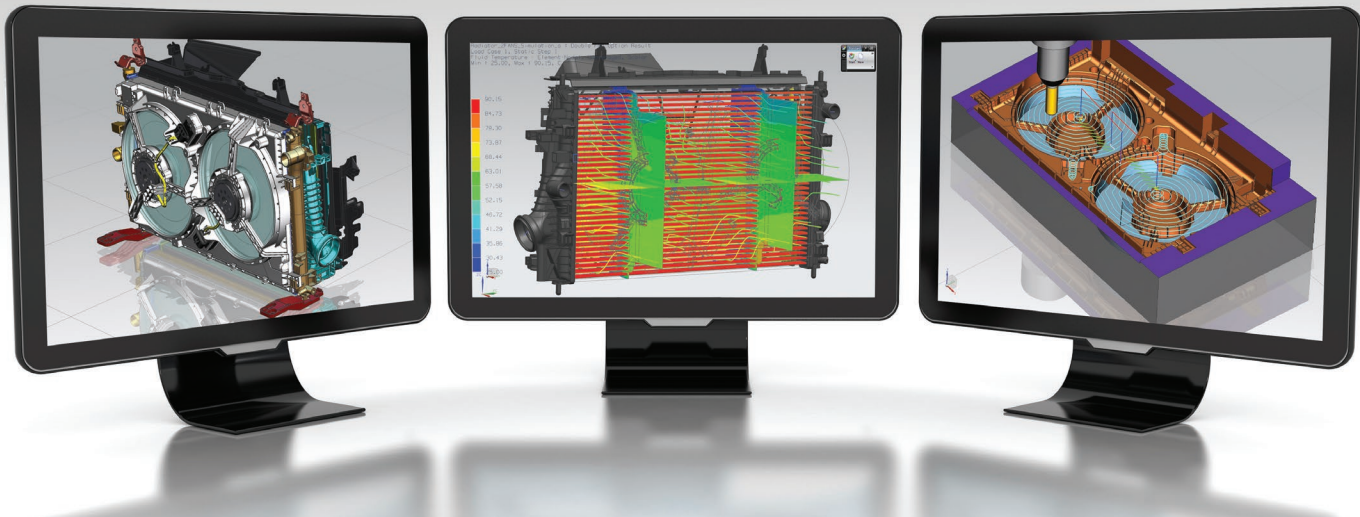

NX provides a unified platform for product development with advanced solutions for design, simulation and manufacturing.

## Unmatched capabilities

No other solution offers a more comprehensive or powerful toolset for product development.

NX delivers:

- Advanced solutions for conceptual design, 3D modeling and documentation
- Multidiscipline simulation for structural, motion, thermal, flow, multiphysics and optimization applications
- Complete part manufacturing solutions for tooling, machining and quality inspection

## Fully integrated product development

NX brings together the tools for every development task in a unified solution. All technical domains work concurrently from the same product model data. The seamless integration enables you to rapidly propagate information and process changes across all development disciplines.

NX leverages Teamcenter® software, a collaborative product development management (cPDM) solution from Siemens PLM Software, to establish a single source of product and process knowledge that coordinates all phases of development, standardizes your processes and accelerates decision making.

## Superior productivity

NX uses high-performance tools and leading-edge technology to address extremely complex problems. NX design tools easily tackle complex geometry and massive assemblies. The advanced simulation capabilities in NX handle the most demanding CAE challenges, significantly reducing physical prototyping. NX also enables you to improve your manufacturing by taking advantage of the most advanced tooling and machining technologies.

## Open environment

The open architecture in NX enables you to protect your existing IT investments by readily incorporating solutions from other vendors in the digital product development process.

## Proven results

NX has enabled customers to increase the number of new products; reduce development time by more than 30 percent; shorten design-analysis iterations by more than 70 percent and reduce computer numerical control (CNC) programming time by up to 90 percent.

# NX for design

*“NX is the most powerful design software I’ve ever used. The solid models, the assemblies, all of the things that come together in the modeling aspect produce better results.”*

Chad Schwartz  
Lead Design Engineer  
Wright Medical Technology



## Advantages

- Reduce design time by more than 30 percent
- Increase the number of new product introductions
- Improve team productivity through re-use
- Work seamlessly with data from other CAD systems
- Validate designs against product requirements
- Make smarter design decisions with visual analytics

## High performance product design

NX can help you deliver greater innovation at higher quality and lower cost with comprehensive 3D product design.

With unmatched power, versatility and flexibility, NX gives your design teams the freedom to use the most productive approach for the task at hand. Designers can select wireframe, surface, solid parametric or direct modeling techniques with seamless interchange.

With the synchronous technology in NX, you can create and edit geometry with unparalleled speed and ease, even using models created on other CAD systems.

NX includes powerful assembly design tools with performance and capacity that enable you to work interactively in the full assembly context, even with the most complex models. Assembly navigation, multi-CAD mockup, interference analysis, path planning and other engineering tools accelerate assembly design and improve quality.

For specialized design tasks, NX offers process-specific modeling tools that outperform general purpose CAD for sheet metal design, weld design and electrical and mechanical routing.

NX also offers design templates that help you accelerate design and standardize engineering processes. You can quickly create templates from existing models and easily re-use them for new designs. Templates can also include simulation, drafting, validation and other engineering best practices.

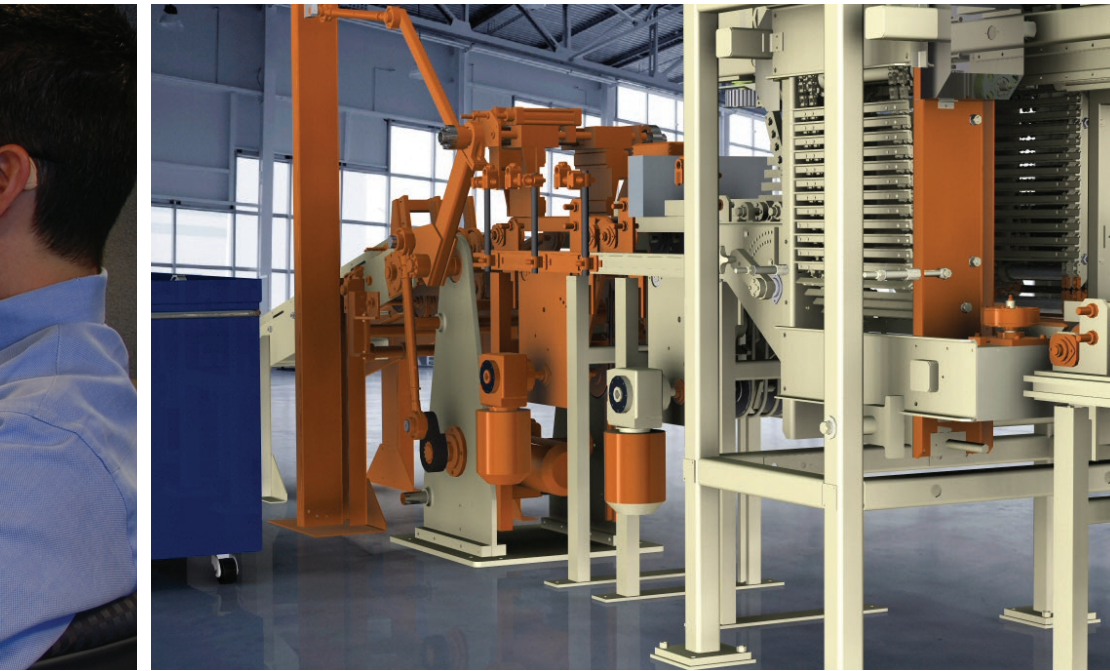

### Integrated industrial design

With advanced freeform modeling, shape analysis, rendering and visualization tools, NX delivers all the capabilities of dedicated industrial design systems, and also offers complete integration with NX design, simulation and manufacturing.

NX freeform modeling gives you the power and creative flexibility to explore alternative design concepts quickly. A versatile, integrated toolset combines 2D, 3D, curve, surface, solid, parametric and synchronous modeling for fast and easy shape creation and editing. You can easily sculpt from basic shapes, or use reverse engineering to create concept models from physical objects.

Shape analysis and validation tools in NX help ensure the integrity, quality and manufacturability of your designs.

### Electromechanical design

NX integrates mechanical, electronic and electrical designs and processes in a unified solution for electromechanical product design.

From printed circuit board design to mechanical packaging and electrical wiring and harness design, NX gives you tools that support collaboration among disciplines. Mechanical, electrical, and control systems designers can use a concurrent process to deliver high-quality products.

To optimize product performance, NX includes simulation solutions that address all major causes of electromechanical product failure.

### Advantages

- Optimize form, fit and function
- Create freeform shapes and iterate concepts faster
- Preserve design intent from concept through production
- Integrate mechanical and electrical disciplines and processes
- Improve ECAD/MCAD information exchange
- Accelerate development and achieve lower costs with concurrent development processes

*“We have no limitation on shape, which is vital to a designer. We are not forced to adapt our design to the tool. We can visualize what the final product could be and have it validated by all the groups involved in the development process, from marketing to manufacturing.”*

Mathias Allély  
Founder  
Keyox

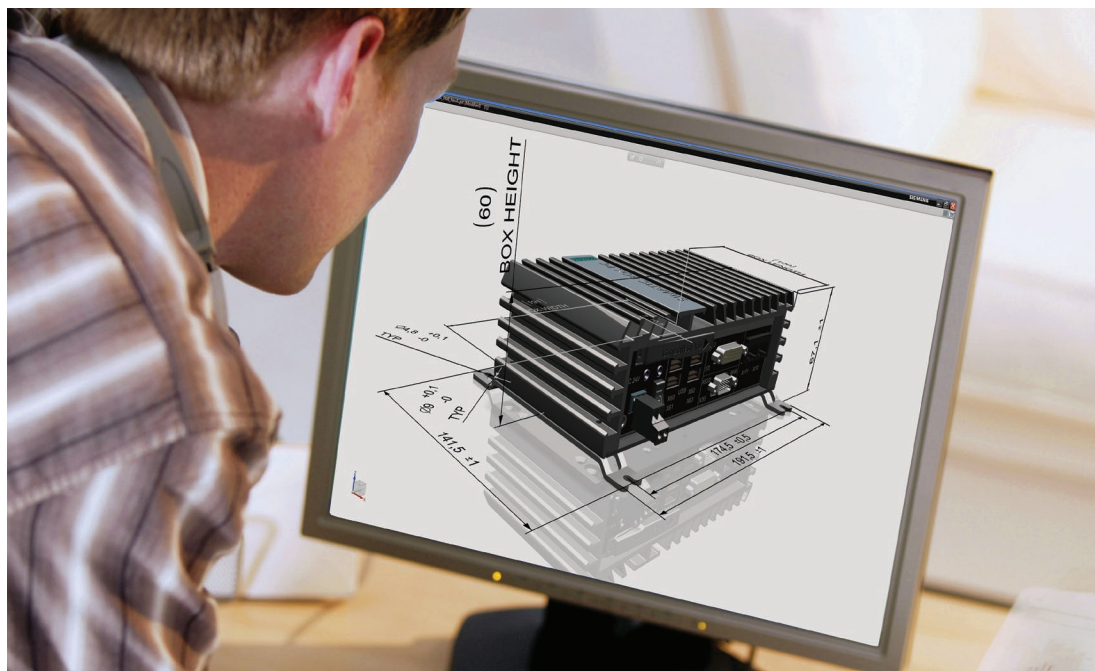

#### Advantages

- Accelerate drawing creation and maintenance
- Ensure accuracy of drawings and compliance with standards
- Increase productivity and quality with 3D annotation
- Enhance design with visual reporting of critical information
- Interpret data quickly and accurately
- Improve decision-making
- Automatically monitor designs for compliance with standards and requirements

#### Drafting and documentation

NX includes powerful capabilities for 2D design, layout, drafting, annotation and documentation.

You can quickly and efficiently create 2D layouts and engineering drawings with highly productive tools that are optimized for 2D and hybrid 2D/3D workflows. Built-in drafting standards ensure that your drawings comply with national and international drafting standards.

With NX, you can fully document designs with 3D annotation on your CAD models. You can re-use the product and manufacturing information in drawings, validation, manufacturing and other applications.

#### Visual analytics and validation

With the visual product analytics and design validation tools in NX, you can quickly synthesize information, check designs for compliance to requirements and make better informed decisions.

NX brings critical product, business and program information to 3D design. With high-definition visual reporting, you can readily answer questions about project status, design changes, team responsibilities, issues, problems, cost, suppliers and other attributes.

Automated validation in NX continuously monitors your designs for adherence to standards and requirements. NX validation checking helps to ensure product quality, eliminate errors and optimize designs for performance and manufacturability.

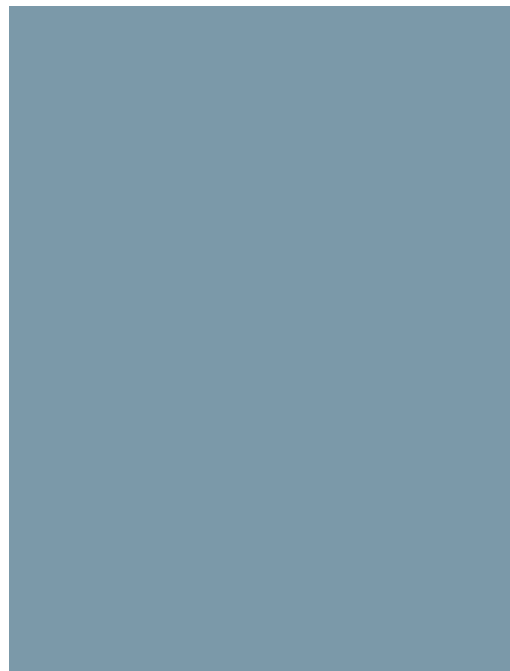
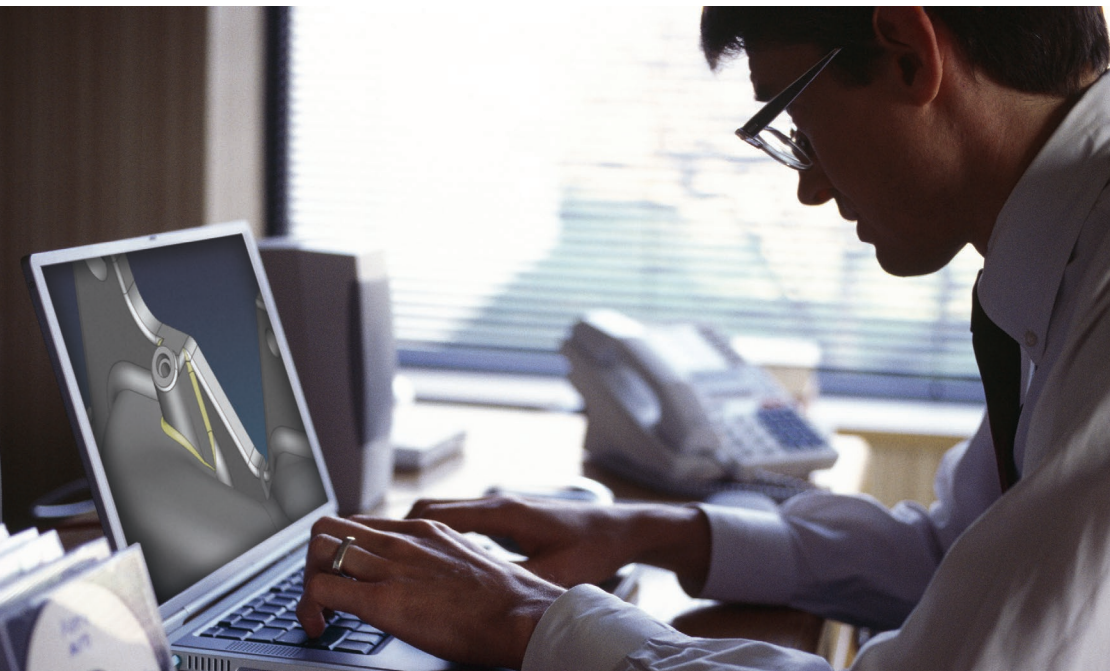

#### Knowledge re-use capabilities

With NX, you can meet higher cost-cutting targets and time-to-market deadlines through re-use. NX helps you capture, manage, locate and re-use a broad range of design information.

A built-in library serves as a centralized repository for models, templates, standard parts, features and other design elements. Designers can quickly locate what they need and use simple drag-and-drop techniques to include objects in new designs.

NX also integrates with Teamcenter and Geolus® Search software to rapidly locate and re-use 3D data. Designers can navigate through classification hierarchies and search for re-usable design information by attribute or shape.

#### Design productivity tools

NX augments design with tools and technologies that help you maximize speed, productivity and efficiency in product development.

Communication, collaboration and data exchange capabilities help you share product information with customers and suppliers, even if they are using different CAD systems.

NX also offers NX Open programming and customization tools to help you extend and tailor software capabilities to your specific needs.

When you move to NX, you can use robust content migration tools to quickly and efficiently leverage your investment in legacy product data, while reducing the time, effort and risk required to re-use information from other systems.

#### Advantages

- Quickly and easily capture, manage, find and re-use design information
- Dramatically reduce development time, cost and effort
- Reduce time to market for product variations
- Easily communicate and collaborate with partners, customers and suppliers
- Automate processes and extend capabilities with programming and customization

# NX for simulation



## Advantages

- Reduce model preparation time by 70 percent
- Shorten design-analysis iterations
- Improve team productivity through capture and re-use of CAE best practices
- Evaluate design trade-offs across multiple disciplines
- Validate and track performance against product requirements

## Smarter engineering decisions

Today's companies want to accelerate innovation by using simulation to evaluate different design alternatives, conduct experiments and gain new insights into product performance. However, some companies are unable to realize the full potential of their simulation investments because simulation continues to be disconnected from mainstream product development. The comprehensive set of NX simulation tools enables you to integrate performance simulation earlier in the development process so you can investigate more design options and make smarter product decisions.

## A modern CAE environment

NX CAE is a modern, multi-discipline environment for advanced analysts, workgroups and designers who need to deliver high quality performance insights in a timely fashion to drive smarter product decisions. Unlike disconnected, single-discipline CAE tools, NX CAE integrates best-in-class analysis modeling with simulation solutions for structural, thermal, flow, motion, multiphysics and optimization into a single environment. It also seamlessly integrates simulation data management into an analyst's workflow so that information is no longer lost within some obscure hard drive. Finally, NX CAE enables simulation-driven design by giving companies the ability to expand simulation to the design community and increase collaboration between analysts and designers.



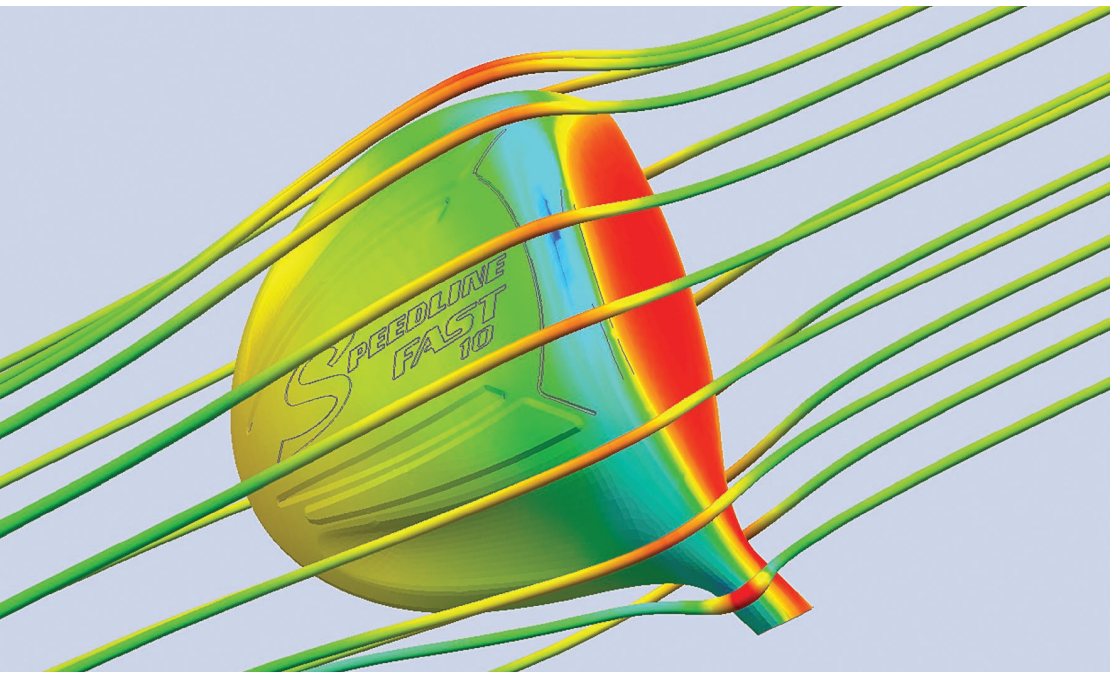

*“We can take our 3D model, basically use that exact same 3D model, just click a button on the NX screen and we’re in stress and strain analysis. Click another button and we’re in a deflection analysis. Click another button and we’re running flow simulations. So being able to integrate all those different analysis tools right into our 3D modeling software has benefited us greatly as well.”*

*Jeff Albertsen  
Design Engineer  
Adams Golf*

#### **Best-in-class analysis modeling**

NX CAE drastically reduces the time engineers spend preparing simulation models. It delivers all the advanced meshing, boundary conditions and solver interfaces that are needed to conduct high-end analysis. What makes NX CAE different from all other preprocessors is its superior geometry foundation, including synchronous technology, which enables intuitive, direct geometry editing. Coupling that with an analysis model to design geometry associativity means that analysis models immediately update to the latest design variant with little to no rework required by the analyst. The tight integration of a powerful geometry engine with robust analysis modeling commands is the key to reducing modeling time by up to 70 percent compared to traditional finite element (FE) modeling tools.

#### **Multidiscipline simulation and optimization**

NX CAE delivers breadth and depth of analysis capabilities through a single, advanced simulation environment. Simulation solutions available include structural, thermal, flow, motion, optimization and multiphysics analyses. The benefit of integrating all these solutions is that engineering departments can standardize their tools on a single platform, which lowers training costs and streamlines coupled and multiphysics analysis workflows. Since all the data is internal, there are no error-prone and time-consuming data transfers between software tools.

NX CAE supports other well-known solvers so you can still leverage existing simulation investments.

#### **Advantages**

- Defeature and prepare geometry faster
- Quick, intuitive direct geometry editing using synchronous technology
- Comprehensive automatic and manual meshing for 0D, 1D, 2D and 3D elements
- Associate analysis model with design geometry for rapid updates
- Supports third-party solvers Abaqus, ANSYS, MSC Nastran and LS-Dyna
- Simulation solutions for structural, thermal, flow, motion, optimization and multiphysics analyses

*“Our analysts are very excited about being able to use synchronous technology to defeature models and get the geometry down to what they need to build a finite element model, a CFD model or a thermal model.”*

Nathan Christensen  
Senior Manager, Engineering  
Tools & Analysis  
ATK

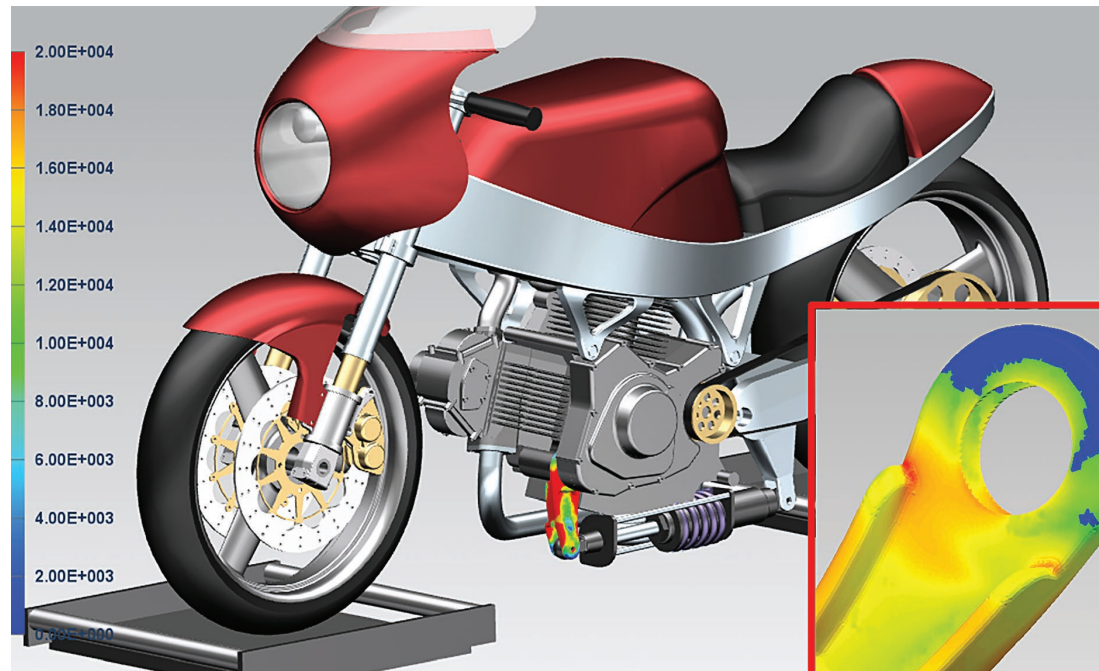

#### Advantages

- Efficiently build and manage FE assemblies through a unique, multilevel approach
- Speed solution times through parallel processing
- Simulate mechatronic systems
- Simulation data and process management
- Out-of-the-box integration with Teamcenter
- Capture and automate repetitive simulation processes

#### Systems-level modeling and simulation

Engineers are continually seeking to better understand product performance at the whole system level, and NX CAE delivers methods that enable easier systems simulation.

NX CAE is unique in the way it manages large FE models. NX CAE uses a multi-level, hierarchical structure, very similar to how a CAD assembly is managed, to efficiently build and manage large analysis model assemblies. This allows engineers to rapidly build FE assembly models simply by referencing and instancing separate FE components.

For mechatronic systems, NX CAE can co-simulate mechanical systems combined with control systems designed in Matlab/Simulink.

#### Simulation data and process management

NX CAE seamlessly integrates with the simulation process management module of Teamcenter. Simulation data management capabilities can be used out-of-the-box, and companies can implement a complete environment for managing CAE data, processes and workflow as part of a wider product development environment. This reduces wasted time by promoting re-use of existing designs and engineering knowledge. Simulation data management also synchronizes simulation with design and makes simulation results readily accessible for data mining, visualization and reporting.

NX Open, the common foundation for automation and programming in NX, can be used to create and automate customized CAE processes to increase productivity.

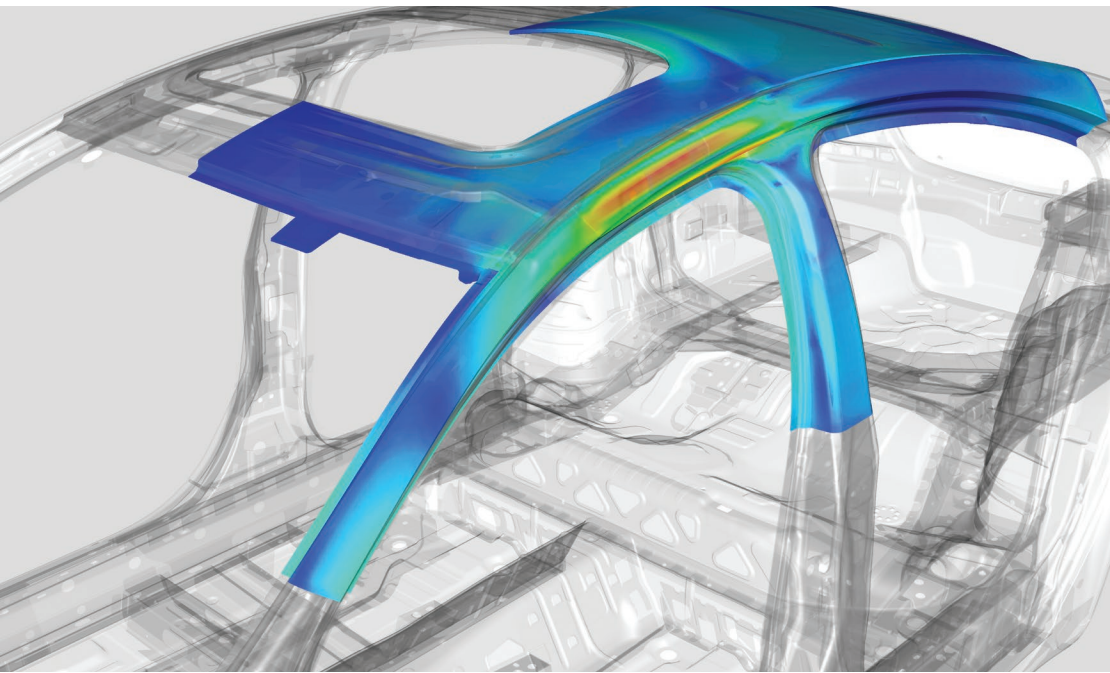

### Simulation-driven design

Simulation has proven to be a time- and cost-effective alternative to physical testing – allowing more design options to be considered in shorter time frames. Today, companies are seeking to further expand the use of simulation by bringing it forward even earlier in the design process. However, the challenge of implementing a simulation-based design strategy includes the absence of an engineering environment and process that can keep pace with the design team.

NX CAE helps facilitate simulation-driven design. Since NX CAE is based on the same platform as NX CAD, simulation capabilities easily scale to a designer's environment and expertise level, while still providing the same trusted simulation technology used by expert analysts.

### CAE vision and heritage

Our vision is to deliver engineering simulation solutions that drive product performance decisions across the complete product lifecycle.

Siemens PLM Software executes on this vision by building upon our simulation heritage that spans 40 years and encompasses well known industry brands, such as Nastran for finite element analysis and I-deas for integrated CAD and CAE. Siemens PLM Software continues to invest in advancing simulation technology and today delivers NX CAE, a modern simulation environment.

### Advantages

- Same scalable technology used by expert analysts and designers
- Perform basic analysis within designer's CAD environment
- Make smarter engineering decisions earlier

# NX for manufacturing



## A single system for manufacturing engineering

NX provides a complete set of numerical control (NC) programming capabilities in a single CAM system as well as an integrated set of manufacturing software applications.

These powerful applications facilitate part modeling, tool design and inspection programming – all based on the proven, future-proof architecture of NX.

NX allows the use of a common 3D model from part design to production. Advanced model editing, tool and fixture design, part and inspection programming are all associative, enabling fast, easy changes.

## Data and process management

Teamcenter provides data and process management for the NX applications. Each piece of information is intelligently connected to form a manufacturing plan.

This helps you to eliminate the need for multiple databases, re-use proven methods, manage tooling and connect the work package directly to the shop floor.

## A scalable solution

From individual applications, such as CAM, NX can be expanded to establish a complete part manufacturing solution that includes a connection to the shop floor systems and equipment. NX is used for manufacturing engineering in a wide range of industries globally, from the smallest shops to the largest corporations.

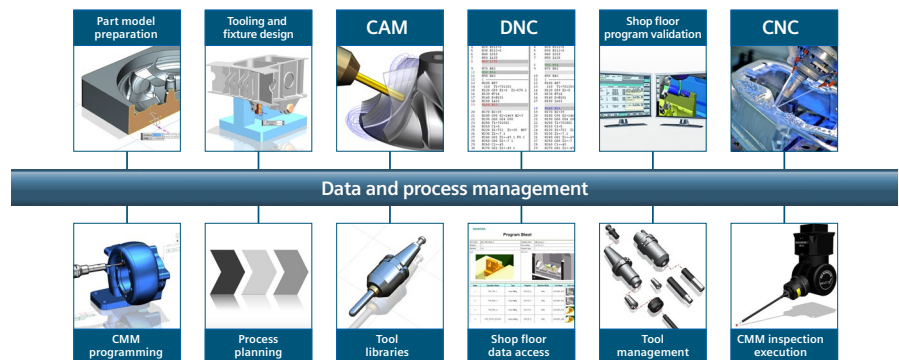

# CAM

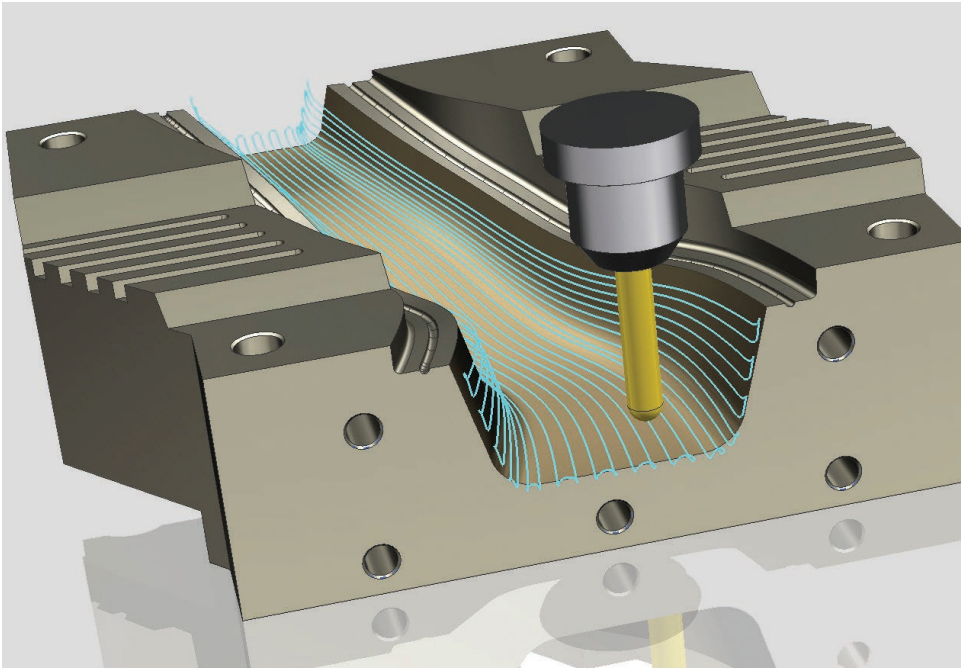

*“With NX, we are reducing our programming time by more than 50 percent.”*

*Rajiv Kapoor  
Managing Director  
Rasandik Engineering  
Industries India Ltd.*

## Advanced programming capabilities

NX CAM provides a wide range of functionality, from simple NC programming to high-speed cutting and multi-axis machining, enabling you to address many tasks using one system.

Improve your productivity further with application-specific programming, such as the volume-based milling used for faster programming of prismatic parts.

## Programming automation

With feature-based machining, programming time can be reduced by as much as 90 percent.

Wizards and templates streamline typical programming processes.

## Postprocessing and simulation

NX CAM has a tightly integrated post-processing system.

The integrated G-code-driven simulation eliminates the need for separate simulation packages.

## Ease of use

For maximum productivity, you can work on the system graphically. For example, selecting and moving the 3D model of the tool to create a tool path is a fast and intuitive way to drive the system.

## CAD for the NC programmer

Rapidly prepare any part model for NC programming with the latest CAD technology in NX.

## Advantages

- Take advantage of the latest machine tool technologies and manufacturing processes
- Save up to 90 percent on programming time by automating routine tasks
- Get it right the first time on the shop floor by simulating and validating NC programs in the context of the machine tool process

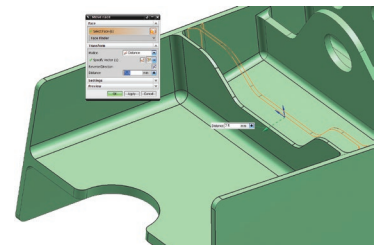

# Tooling and fixture design, quality inspection

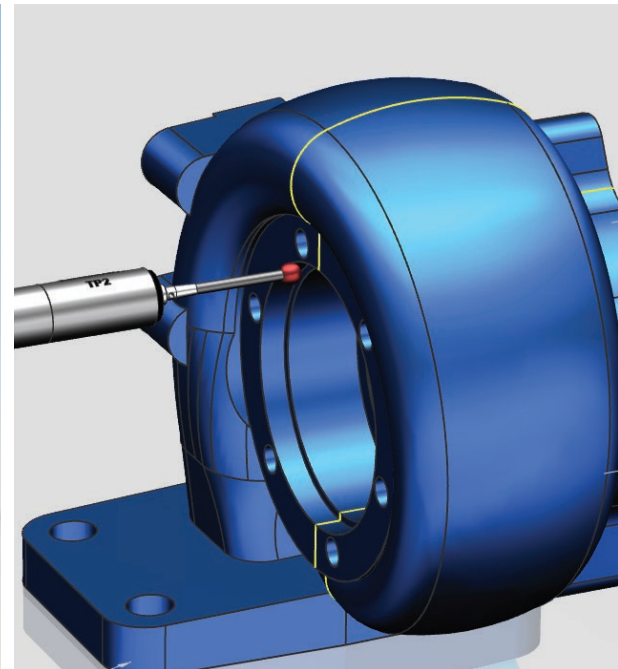
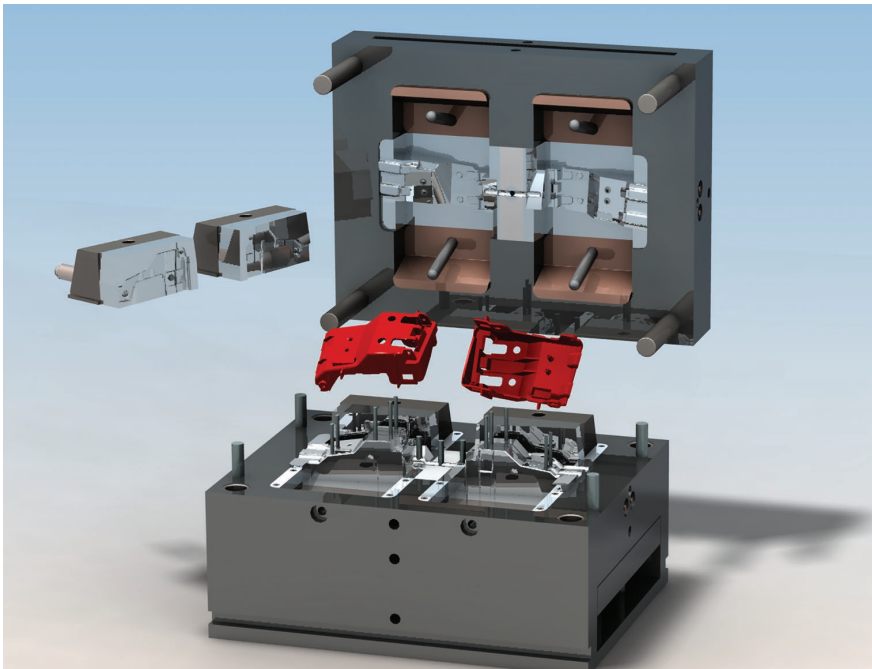

## Advantages

### Tooling and fixture design

- Automate your tool and fixture design process
- Capture tooling design knowledge and re-use proven designs
- Virtually prototype functional operation of tooling and fixtures

### CMM inspection programming

- Reduce CMM programming time by up to 80 percent
- Ensure all part requirements are inspected according to company standards
- Facilitate fast and efficient design change propagation across entire process

### Tooling and fixture design

*NX Mold Design* automates the entire process of designing the parting line and surfaces, core and cavity, and mold base directly from the part model. Check designs and evaluate design alternatives with the integrated mold flow simulation.

*NX Progressive Die Design* includes expert die-making capabilities that enable the automation of the design process.

*NX Stamping Die Design* provides advanced capabilities for formability analysis, die planning, die face design and die structure design.

*NX Electrode Design* incorporates numerous industry best practices into a step-by-step approach that automates the design of electrodes.

*Fixture design* includes fully associative component design, assembly positioning and mating, kinematic simulation and performance validation capabilities.

### CMM inspection programming

*NX coordinate measuring machines (CMM) Inspection Programming* streamlines the entire inspection program development process.

Use product and manufacturing information (PMI) on the model (including GD&T and 3D annotation) to automatically generate programs.

Generate postprocessed output, including the DMIS standard and machine-specific formats.

With the integrated inspection analysis you can read back measured data for comparison and study.

# Connecting planning to production



NX for manufacturing applications

Teamcenter



Connect PLM to Shop floor

Machine tool equipment and personnel



## Shop Floor Connect for Teamcenter

Shop Floor Connect (SFC) for Teamcenter is an add-on for Teamcenter.

With SFC for Teamcenter you can access and view work package data on any browser-enabled device connected to the network. This could include a wide range of manufacturing information, including shop documentation, tool lists, setup sheets, pictures and drawings.

Also, SFC for Teamcenter allows delivery of CNC program files from Teamcenter directly into the machine controller with no local data storage.

More than just a traditional direct numerical control (DNC) system, the connection to the secure Teamcenter database avoids data duplication and manages revisions to make sure the correct manufacturing data is used on the shop floor.

## NX for Siemens Sinumerik controllers

NX CAM provides optimized output for Sinumerik controllers. You can select a range of special Sinumerik functions or cycle commands with the correct parameters in order to maximize machine tool performance.

The PostBuilder application that comes with NX CAM includes advanced templates from which comprehensive postprocessors for Sinumerik controllers can be developed.

In some cases, advanced postprocessors and simulation kits have been developed by working with the machine tool builders.

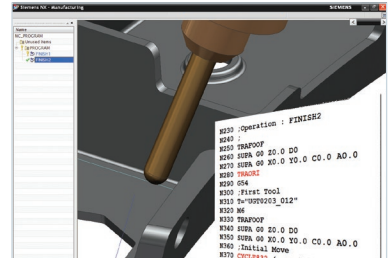

*“Due to the direct access to PLM information on the shop floor, our machines’ idle times are significantly reduced.”*

*Hans-Juergen Steeb  
Manager of IT and Organization  
ANDRITZ Ritz*

## About Siemens PLM Software

Siemens PLM Software, a business unit of the Siemens Digital Factory Division, is a leading global provider of product lifecycle management (PLM) and manufacturing operations management (MOM) software, systems and services with over nine million licensed seats and more than 77,000 customers worldwide. Headquartered in Plano, Texas, Siemens PLM Software works collaboratively with its customers to provide industry software solutions that help companies everywhere achieve a sustainable competitive advantage by making real the innovations that matter. For more information on Siemens PLM Software products and services, visit [www.siemens.com/plm](http://www.siemens.com/plm).

### Headquarters

Granite Park One  
5800 Granite Parkway  
Suite 600  
Plano, TX 75024  
USA  
+1 972 987 3000

### Europe

Stephenson House  
Sir William Siemens Square  
Frimley, Camberley  
Surrey, GU16 8QD  
+44 (0) 1276 413200

### Americas

Granite Park One  
5800 Granite Parkway  
Suite 600  
Plano, TX 75024  
USA  
+1 314 264 8499

### Asia-Pacific

Suites 4301-4302, 43/F  
AIA Kowloon Tower,  
Landmark East  
100 How Ming Street  
Kwun Tong, Kowloon  
Hong Kong  
+852 2230 3308

© 2015 Siemens Product Lifecycle Management Software Inc.

Siemens and the Siemens logo are registered trademarks of Siemens AG. D-Cubed, Femap, Fibersim, Geolus, GO PLM, I-deas, JT, NX, Parasolid, Solid Edge, Syncrofit, Teamcenter and Tecnomatix are trademarks or registered trademarks of Siemens Product Lifecycle Management Software Inc. or its subsidiaries in the United States and in other countries. All other logos, trademarks, registered trademarks or service marks belong to their respective holders.

4639-X51 12/14 B